

BeeLine 2M HP GPS User's Guide

V0.2

November 5, 2008

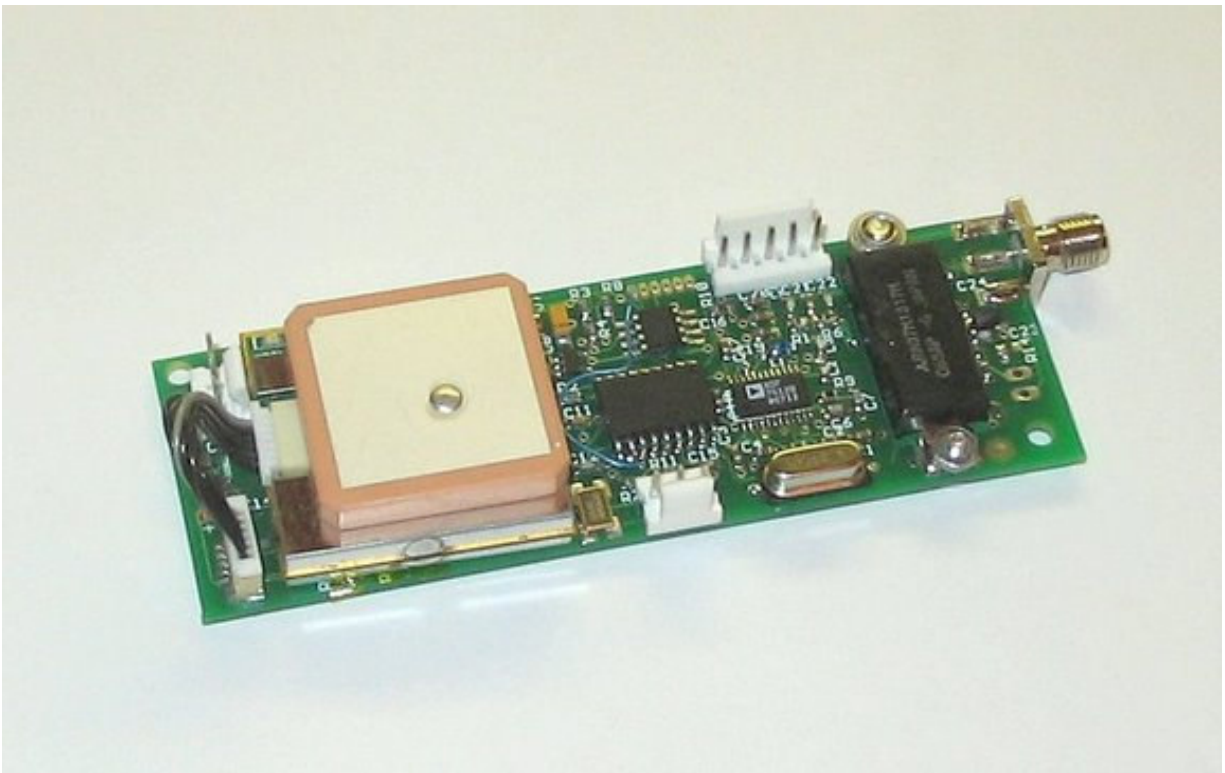

1 Overview

The BeeLineGPS 2MHP is a small, highly integrated GPS and 2 meter radio design to receive GPS positions and broadcast APRS packets. It integrates a GPS, TNC (terminal node controller) and 5 watt RF transmitter into a single circuit board. Position can be sent at user defined intervals or use Smart Beacons™. The BeeLineGPS can also be configured for timeslotting, allowing multiple devices to transmit on the same frequency without transmitting at the same time. On board non-volatile memory can also record up to 1000 positions, and can be read back and viewed with Google Earth.

The design, layout and functionality are very similar to 70cm transmitters from BigRedBee. Please see the corresponding documentation (<http://www.bigredbee.com/BeeLineGPS.htm>) for a description of device pin outs, data packet formats, battery charging and firmware updates.

2 Feature Comparison

	TX Frequency	RF Max Power	GPS Module	Digital Telemetry	Launch Detect
BLGPS 2M HP	144-148 Mhz	5 watts	Sirf III / Lassen IQ	No	No
BLGPS 70cm	420-450 Mhz	16 mwatts	Trimble Lassen IQ	Yes	Yes

Trimble Lassen IQ is confirmed to work above 18000 meters.

Sirf III is confirmed to NOT work above 18000 meters.

Lassen IQ is qualified for operations involving fast changing altitude (ie, High Power Rocketry)

GPS Modules

The BeeLineGPS 2MHP can be configured with either a Lassen IQ or a SiRFstar III GPS module.

The Lassen IQ is recommended for airborne operation. It has user configurable filter parameters that allow it to better track objects with rapidly varying altitudes, such as rockets or balloons. It also operates above 18,000 meters, whereas the SiRFstar III GPS module does not. This receiver typically requires a clear view of the sky to obtain a GPS lock.

The SiRFstar III modules do NOT work above 18,000 meters, and are recommended for ground based tracking.. The SiRFstar III module has very high receiver sensitivity, allowing it lock inside some buildings without a clear view of the sky.

3 Power Up Sequence

The power up sequence begins when power is applied to the device.

- A 5 second delay occurs to allow the boot loader to gain control if necessary. Programming commands issued to the device may be ignored during this time.
- The status LED near the SMA antenna connector will blink three times, power to the GPS is enabled, and the LED on the GPS will turn on.
- The RF subsystem is initialized, and the board is now in *run mode*.
- The LED on the GPS will be ON until it obtains a good lock on the satellites required to obtain a fix, and then blink at a rate of once per second once (SiRFstar III only)

While in RUN mode, the unit will transmit packets, and store data into the onboard memory at the rate specified by the programming utility. The status LED will turn on while transmitting if the amplifier is enabled.

4 Programming Software

The BeeLine GPS programming software is available for download here:

<http://www.bigredbee.com/software.htm>.

5 Programing information

Once the device is in *run mode*, the programming utility can be used to view or modify the device parameters. Always issue a READ command first. Once a READ command has been issued, the device will be in *command mode*. While in *command mode*, no packets will be transmitted, and no data will be stored into the onboard memory

Read and write commands can now be utilized to modify and/or verify the device configuration.

To return to *run mode*, it is necessary to push the RUN button on the programming interface, or cycle the power.

Transmitter Control

- **Com port:** Set the proper serial port. If you need a com port # that is not available in the drop-down menu, simply type the desired value into the text box.
- **Frequency:** This is the RF carrier frequency the packet will be sent out on. Possible values are between 144 and 148 Mhz
- **Output Power:** Set between -10 dBm and 12 dBm
- **Deviation:** Controls RF transmitter deviation. Default value is 8 (4.5 KHz) , do not change.
- **Preamble:** Number of IDLE characters sent before start of packet data: Default value is 20, do not change.
- **Low V Shutdown Enable:** Set this option if you wish the microcontroller to shut down the transmitter and GPS when the voltage gets below the value you set in “Low V”.

The screenshot shows the 'BeeLine GPS Communicator' software interface. It features a blue title bar and a light-colored background. The interface is organized into several sections. At the top, there are fields for 'COM port' (a dropdown menu set to 'COM1'), 'Frequency' (144.390 Mhz), and 'Output Power' (12 dBm). To the right, it displays device information: 'Model: BLGPS9', 'Version: 109', 'Ser#: 100', and 'Battery 5.67 V'. Below these are buttons for 'Read', 'Write', and 'Run'. The middle section contains 'Deviation' (10), 'Preamble' (20), 'Low V' (3.50), and a checkbox for 'Low V shutdown enable'. The next section has 'ID String' (K7RKT), 'SSID' (2), 'Symbol' (-), and 'TimeSlot' (0). Below that are 'Path' fields (WIDE1 1, WIDE2 1) and 'Store Interval' (5 secs). A large section of checkboxes includes 'Enable Power Amp', 'Enable APRS Packet Format', 'Wrap Data Log', 'Enable Slotting', 'Position Logging On', 'Smart Logging', 'Enable Course/Speed', and 'Disable RF out'. The bottom section has 'Slow Speed' (5), 'Slow Rate' (3600), 'Fast Speed' (60), 'Fast Rate' (60), 'Turn Slope' (255), 'Turn Angle' (22), and 'Turn Time' (5). At the very bottom, there are 'TX Msg' and 'Messages' fields, a 'Time' display (0:00:00), and a 'COM Port Timeout (secs)' field. The footer contains 'Version 27NW - 2/09/2008' and '(C) 2007, 2008 BigRedBee, LLC'.

Information

- **Model Number:** BLGPS9 for the 2-Meter Amplified version
- **Version:** Firmware version
- **Serial Number:** The serial number stored in read only memory
- **Battery:** Current battery voltage

APRS parameters

- **ID String:** Your amateur radio callsign. Not more than 6 characters in length
- **SSID:** The SSID in the APRS packet. The default is 1, possible values are 1 thru 15
- **Symbol:** The symbol character in the APRS packet. The default is ‘-‘
- **TimeSlot:** Number of seconds to delay if slotting is enabled.

- **Path:** Each is 7 characters in length. If you're not familiar with AX-25 digipeating protocols, it's best to leave these values alone. *Placing an 'X' in the first character of the first path will eliminate BOTH paths from the transmitted packet Placing an 'X' in the first character of the second path will eliminate only second patch from the transmitted packet.*
- **Store Interval:** Number of seconds between position writes to on-board memory

Misc Controls

- **Enable Power Amp:** Disable for testing, must be enabled during normal use
- **Enable Slotting:** Turn Time Slotting On.
- **Position Logging On:** Position and altitude data will be logged into o-board memory.
- **Enable Course/Speed:** The course and speed are transmitted as part of the data packet
- **Disable RF Out:** Disables RF transmissions
- **Wrap Data Log:** When set, data is overwritten starting at the beginning after the end is reached.
- **Smart Logging:** See below

Smart Beacons Parameters

SmartBeaconing is an algorithm created by Steve Bragg for adjusting the transmit rate by monitoring the speed and heading from the GPS. SmartBeaconing also uses corner pegging to cause transmissions to occur when the heading changes.

- **Slow Speed:** Lower speed limit (MPH)
- **Slow Rate:** Beacon rate if speed is below "Slow Speed"
- **Fast Speed:** Upper speed limit (MPH)
- **Fast Rate:** Beacon rate if speed is above "Fast Speed"
- **Turn Slope:** The lower the slope, the quicker the BeeLine will transmit due to turning
- **Turn Angle:** Turns less than the turn angle will not be transmitted
- **Turn Time:** Transmissions will not occur within TURN TIME from last transmission.

On-board memory

The BeeLine GPS includes non-volatile memory for periodic storage of GPS data. Writing always starts at location 0 when power is applied. The previous contents of memory are overwritten.

- **Read Flash:** Data memory is read from the BeeLine GPS and stored to disk in the working directory in a file called beegps.kml. If the file exists, an error is displayed. The .kml file is an ASCII file with headers and footers designed to be compatible with Google Earth.
- **Clear Flash** Erases the on-board flash memory

6 Smart Beacons

Following is a representation of the smart Beacons algorithm.

```

IF (speed < low_speed)
{
    beacon_rate = slow_rate;
}
ELSE
{
    IF (speed > high_speed) // Adjust beacon rate according to speed
    {
        beacon_rate = fast_beacon_rate;
    }
    ELSE
    {
        beacon_rate = fast_beacon_rate * high_speed / speed;
    }

    // Corner pegging - ALWAYS occurs if not "stopped"
    // Note turn threshold is speed-dependent

    turn_threshold = turn_min + turn_slope / mph;

    IF ((heading_change_since_beacon > turn_threshold) AND
        (secs_since_beacon > turn_time))
    {
        secs_since_beacon = beacon_rate;
    }
}

IF (secs_since_beacon > beacon_rate)
    // ... send beacon

```

More information on SmartBeaconing can be found at <http://www.hamhud.net> .

Here are some suggested values for the various smart beaconing parameters.

Slow Speed: 5	Slow Rate: 3600	
Fast Speed: 60	Fast Rate 60	
Turn Slope: 255	Turn Angle: 22	Turn Time: 5

If your speed is less than 5 mph, transmit once per hour (3600 seconds). If your speed is between 5 and 60, transmit once every minute if speed is greater than 60, and longer if your speed is between 5 and 60 (beacon rate = Fast Rate * Fast Speed / actual speed)

If your speed is greater the 5 MPH, also transmit when the heading changes by more than 22 degrees, but not more often than once every 5 seconds.

7 Periodic Operation

Smart beaconing can NOT be disabled. If periodic operation is desired, then set both the “slow speed” and “high speed” to a large value such as 100. Here are some settings which would produce a constant transmit rate of once per minute regardless of speed.

Slow Speed: 100
 Slow Rate: 60
 Fast Speed: 100
 Fast Rate 60

8 Time Slotting

Time slotting is a method which allows multiple transmitters to share the same frequency, and should only be used with periodic operation. If Time Slotting is enabled, the transmitters will synchronize their transmit times to the GPS clock.

For example, if you set up a transmitter 'A' for periodic operation every 30 seconds, set the time slot to 10 and enable slotting, it will transmit at 10 and 40 seconds past the top of every minute.

If you then set up a transmitter 'B' or periodic operation every 30 seconds, set the time slot to 5 and enable slotting, it will transmit at 5 and 35 seconds past the top of every minute.

9 APRS symbols

The default '-' symbol will show up as a house. Change it to 'O', for example, to display a balloon.

Only the primary APRS symbol table is implemented.

!	"	#	\$	%	&	'	()	*	+	,	-	.	/	0
1	2	3	4	5	6	7	8	9	:	;	<	=	>	?	@
A	B	C	D	E	F	G	H	I	J	K	L	M	N	O	P
Q	R	S	T	U	V	W	X	Y	Z	[\]	^	_	`
a	b	c	d	e	f	g	h	i	j	k	l	m	n	o	p
q	r	s	t	u	v	w	x	y	z	{		}	~		

Choosing a character from the table above causes the symbol in the corresponding position from one of the tables below to be displayed. The cross-hair symbols occupy symbol slots that have not yet been assigned.

				DX										
1	2	3	4	5	6	7	8	9						
	RRS							TSP						
	RV													
			FIRE									MIC		
			TS											REV

10 Power

Power is delivered via the 3-pin connector near the bottom of the board. Two power input modes are available.

10.1 Low Voltage Input

This pin is intended to be used for truly portable operation. The input voltage in this mode is a minimum of 4 V volts and a maximum of 9.6 Volts. This input pin directly powers the RF amplifier and 3.3volt regulator that in turn drive the GPS, microcontroller, and RF sub-sections.

Use this power input pin for battery operated applications.

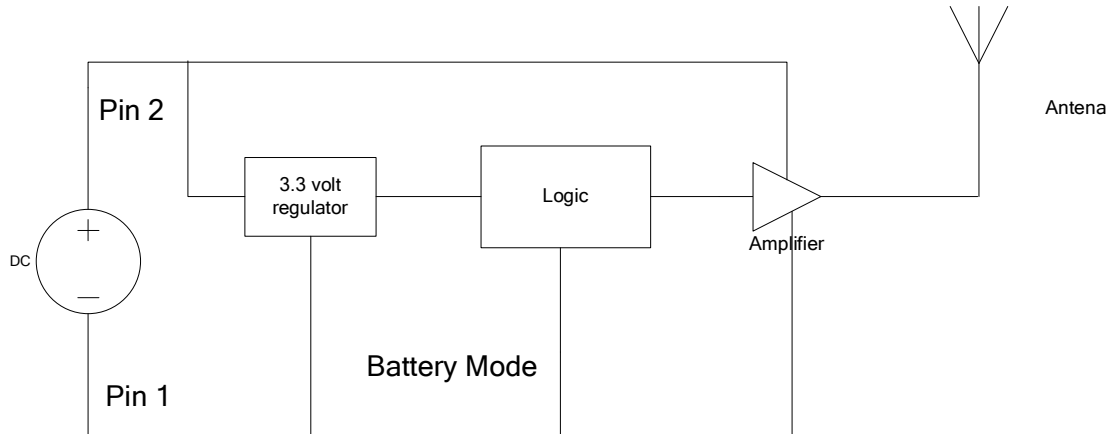

10.2 Hi Voltage Input

This pin is intended to be used for mobile operation and can be plugged directly into an automobile cigarette lighter, or any other unregulated 12 Volt power source. The input voltage in this mode is a minimum of 9 volts, and a maximum of 16 volts. This input drives a 7.5V regulator, which is then routed to the RF amplifier, and also to the 3.3 V regulators as described above.

Use this power input pin for operation from a 12V supply.

If the Hi Voltage input mode is not needed, the large regulator and heat sink on the back of the board may be removed.

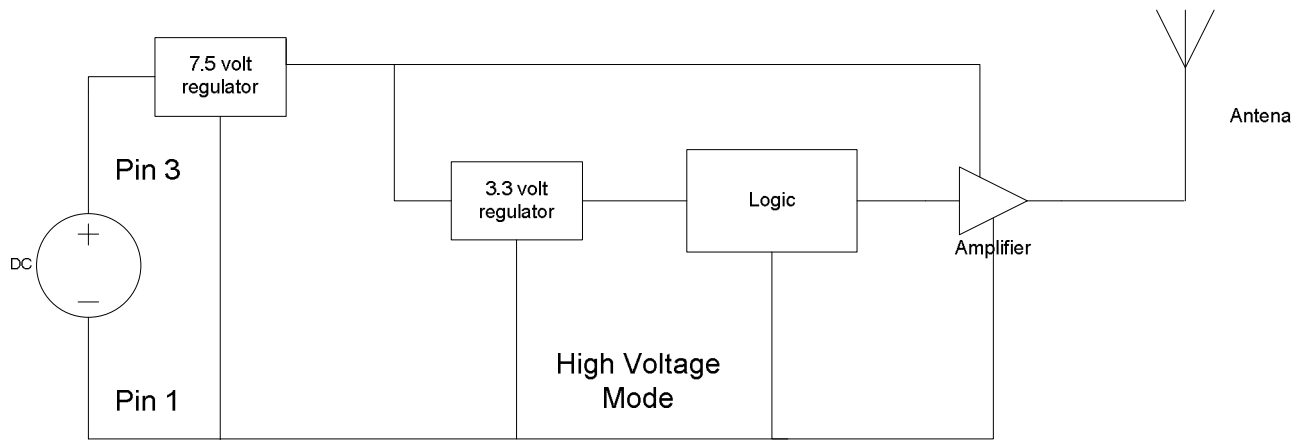

10.3 Power Delivery Summary

There are several ways to power the BeeLine GPS.

- 1) Supply no less than 4.0 Volts to pins 1 and 2 as mentioned in section 10.1. This will result in approximately 1 watt of RF output. It is important that the input voltage not drop below 4V or the output power will drop dramatically. The power regulator is not required in this mode of operation and may be removed if necessary.
- 2) Supply no less than 7.5 Volts and no more than 9.0 Volts to pins 1 and 2 as mentioned in section 10.1. This will result in approximately 5 watts of RF output. The power regulator is not required in this mode of operation and may be removed if necessary. Voltage levels between 4.0 V and 7.5V will result in RF output levels of between 1 and 5 watts.
- 3) Supply no less than 8.5 Volts and no more than 9.6 Volts to pins 1 and 3 as mentioned in section 10.2. This will result in approximately 5 watts of RF output. The power regulator is required, but the heatsink is not required and may be omitted if necessary.
- 4) Supply up to 15.0 Volts to pins 1 and 3 as mentioned in section 10.2. This will result in approximately 5 watts of RF output. The power regulator is required. The heatsink is required.

11 Model and Version Numbers

With the introduction of new hardware to support high RF power output levels and 2 meter / 70 centimeter version, there are now many different models available. The model number and firmware revision will be visible in the windows programming utility and are summarized here

Model Number	Frequency (Mhz)	Amplified?	Digital Telemetry?	12.5V Operation	RF chip
BLGPS0	440	No	Yes	No	CC0150
BLGPS1	440	Yes	G-switch	No	CC0150
N/A	144	No			ADF7012
BLGPS9	144	Yes	No	Yes	ADF7012
N/A	440	No			ADF7012
BLGPSB	440	Yes	No	Yes	ADF7012

It is important to note that even though the PCB's for model numbers BLGPS9 and BLGPSB are the same, the component values differ slightly. It is not possible to load firmware intended for the BLGPS 9 board onto the BLGPSB board.

12 Firmware upgrade

The firmware upgrade utility is a Windows Console application. Open a command window (Start->Run->cmd), and make sure that the flash utility (beeflash.exe) and the appropriate .hex file are in the same directory.

The command line is:

```
C:> beeflash.exe <comm port> <hexfile> [-v]
```

For example:

```
C:> beeflash.exe com1 gspfsk.hex
```

- 1) Remove all power connectors and cables
- 2) Connect the serial interface to the PC
- 3) Plug the serial interface into the BeeLine GPS
- 4) Invoke the flash upgrade utility
- 5) Follow the on-screen directions.

The flash programming utility will check the model number of the current board, and ensure that the correct firmware is being loaded. It will also check for incompatible firmware revisions within the same model number.

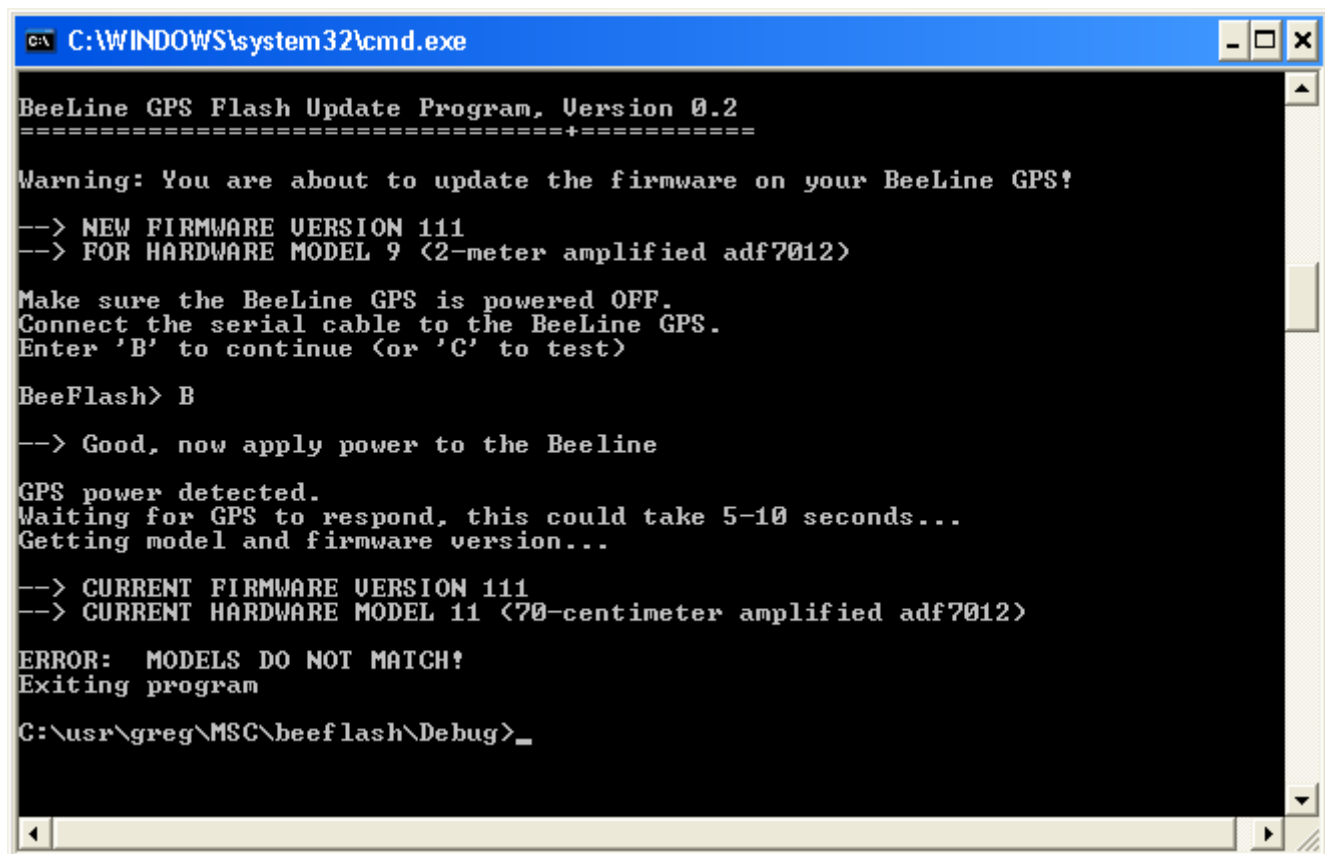

```
C:\WINDOWS\system32\cmd.exe

BeeLine GPS Flash Update Program, Version 0.2
=====+=====

Warning: You are about to update the firmware on your BeeLine GPS!

--> NEW FIRMWARE VERSION 111
--> FOR HARDWARE MODEL 9 <2-meter amplified adf7012>

Make sure the BeeLine GPS is powered OFF.
Connect the serial cable to the BeeLine GPS.
Enter 'B' to continue <or 'C' to test>

BeeFlash> B

--> Good, now apply power to the Beeline

GPS power detected.
Waiting for GPS to respond, this could take 5-10 seconds...
Getting model and firmware version...

--> CURRENT FIRMWARE VERSION 111
--> CURRENT HARDWARE MODEL 11 <70-centimeter amplified adf7012>

ERROR: MODELS DO NOT MATCH!
Exiting program

C:\usr\greg\MSC\beeflash\Debug>_
```

13 Connectors

13.1 Power Connector

(looking down from above)

Pin 1: Battery – (GROUND)

Pin 2: Battery + (Low level Voltage)

Pin 3: Battery + (high level Voltage)

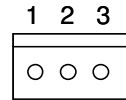

13.2 ICSP Connector

(looking down from above)

Pin 1: TTL level transmit data out (ICSP_DCLK)

Pin 2: TTL level receive data in (ICSP_DATA)

1 2 3

1 2 3 4 5

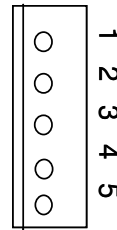

14 Electrical Characteristics

V _{min}	Minimum Voltage Input Level	4.0 Volts
V _{Max} (low V input)	Maximum Voltage Input Level	9.6 Volts
V _{Max} (high V input)	Maximum Voltage Input Level	16 Volts
I _(idle)	Idle Current Draw	100 mAmps
I _(tx)	Transmit Current Draw	approx 2 Amps
P _(l)	Power output at 4 volts	1 watt
P _(h)	Power output at 7.5 volts	5 watts