

BigRedBee 2M HP GPS User's Guide

V0.8

May 2013

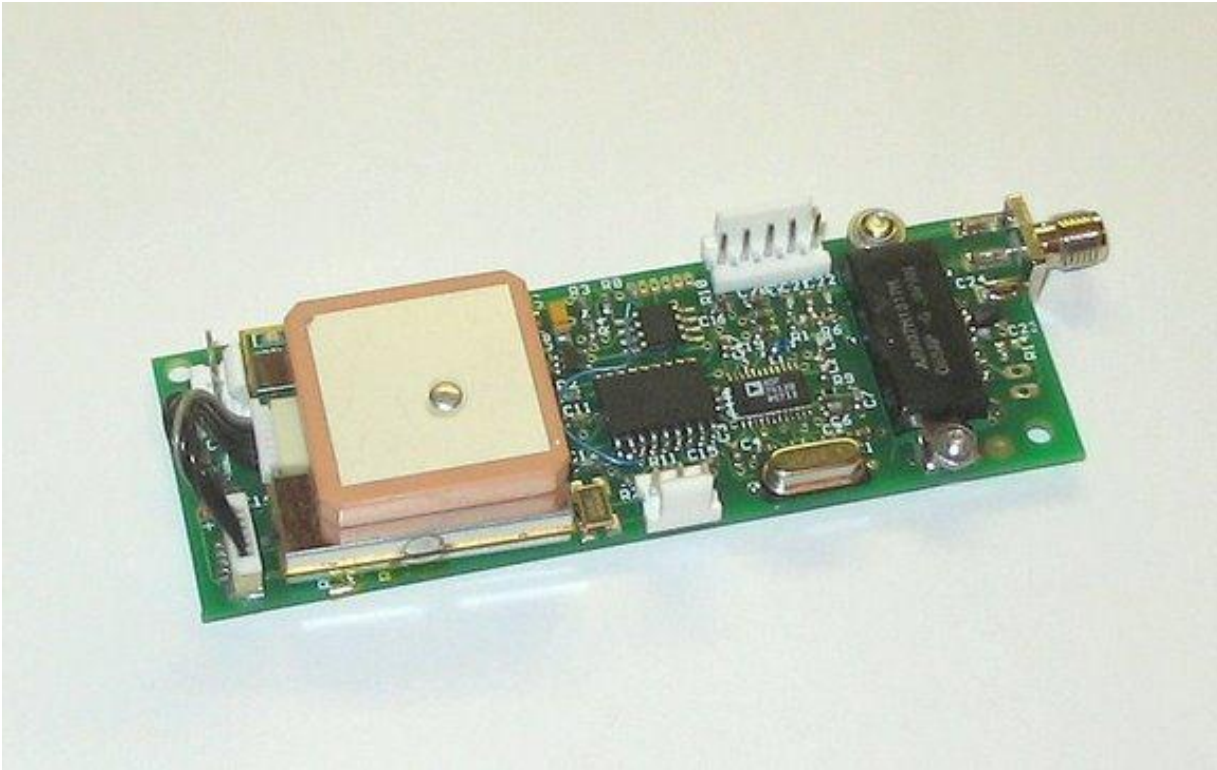

1 Overview

The BeeLineGPS 2MHP is a small, highly integrated GPS and 2 meter radio design to receive GPS positions and broadcast APRS packets. It integrates a GPS, TNC (terminal node controller) and 5 watt RF transmitter into a single circuit board. Position can be sent at user defined intervals or use Smart Beacons™. The BeeLineGPS can also be configured for timeslotting, allowing multiple devices to transmit on the same frequency without transmitting at the same time. On board non-volatile memory can also record up to 8000 positions, and can be read back and viewed with Google Earth.

The design, layout and functionality are very similar to 70cm transmitters from BigRedBee. Please see the corresponding documentation (<http://www.bigredbee.com/BeeLineGPS.htm>) for a description of device pin outs, data packet formats, battery charging and firmware updates.

2 Power Up Sequence

The power up sequence begins when power is applied to the device.

- A 5 second delay occurs to allow the boot loader to gain control if necessary. Programming commands issued to the device may be ignored during this time.
- The status LED near the SMA antenna connector will blink three times, power to the GPS is enabled.
- The RF subsystem is initialized, and the board is now in *run mode*.
- The LED on the transmitter board will be OFF until it obtains a good lock on the satellites required to obtain a fix, and then blink at a rate of once per second.

While in RUN mode, the unit will transmit packets, and store data into the onboard memory at the rate specified by the programming utility.

3 Programming Software

The BeeLine GPS programming software is available for download here:

http://bigredbee.com/blgps_2mhp.htm.

4 Programing information

Once the device is in *run mode*, the programming utility can be used to view or modify the device parameters. Always issue a READ command first. Once a READ command has been issued, the device will be in *command mode*. While in *command mode*, no packets will be transmitted, and no data will be stored into the onboard memory

Read and write commands can now be utilized to modify and/or verify the device configuration.

To return to *run mode*, it is necessary to push the RUN button on the programming interface, or cycle the power.

It is recommended to cycle power after modifying any parameters with the WRITE command

Transmitter Control

- **Com port:** Set the proper serial port. If you need a com port # that is not available in the drop-down menu, simply type the desired value into the text box.
- **Frequency:** This is the RF carrier frequency the packet will be sent out on. Possible values are between 144 and 148 Mhz
- **Output Power:** For the high power 2 Meter version, leave this set to 12 dBm
- **Deviation:** Controls RF transmitter deviation. Default value is 8 (4.5 Khz) , do not change.
- **Preamble:** Number of IDLE characters sent before start of packet data: Default value is 25.
- **Low V Shutdown Enable:** Set this option if you wish the microcontroller to shut down the transmitter and GPS when the voltage gets below the value you set in “Low V”.

Information

- **Model Number:** BLGPS9 for the 2-Meter Amplified version with Trimble Lassen IQ, BLGPS6 for the 2-Meter Amplified version with the u-blox NEO-6
- **Version:** Firmware version
- **Serial Number:** The serial number stored in read only memory
- **Battery:** Current battery voltage

APRS parameters

- **ID String:** Your amateur radio callsign. Not more than 6 characters in length
- **SSID:** The SSID in the APRS packet. The default is 1, possible values are 1 thru 15
- **Symbol:** The symbol character in the APRS packet. The default is ‘-‘
- **TimeSlot:** Number of seconds to delay if slotting is enabled.

- **Path:** Each is 7 characters in length. If you're not familiar with AX-25 digipeating protocols, it's best to leave these values alone.

Misc Controls

- **Store Interval:** Number of seconds between positions writes to on-board memory. *Ignored if Smart Logging is enabled.*
- **Store HM:** By default, the onboard memory only logs the seconds portion of the GPS time. Enabling this option will store the hours and minutes in addition to the seconds
- **Compress Data:** After the initial position is logged, only the fractional portion of the latitude and longitude are recorded. The altitude is not recorded. This increases the number of datapoints that can be stored by approximately 300%.
- **Enable Power Amp:** Disable for testing, must be enabled during normal use
- **Enable Slotting:** Turns Time Slotting On, and transmits at a constant interval determined by the **Slow Rate**. *Smart beaconing is disabled if slotting is enabled.*
- **Position Logging On:** Position and altitude data will be logged into o-board memory.
- **Transmit Course/Speed:** The coarse and speed are transmitted as part of the data packet
- **Disable RF Out:** Disables RF transmissions
- **Wrap Data Log:** When set, data is overwritten starting at the beginning after the end is reached.
- **Smart Logging:** Data is stored into memory at the same time the smart beaconing algorithm triggers the transmission of a packet
- **Transmit Altitude:** The altitude will be transmitter in the comment section of the data packet.
- **Convert Meters to Feet:** The altitude will be converted to feet before it is transmitted.
- **Only Send Valid:** The APRS packet will only be transmitted if the GPS position is valid.

Smart Beaconing Parameters

SmartBeaconing is an algorithm created by Steve Bragg for adjusting the transmit rate by monitoring the speed and heading from the GPS. SmartBeaconing also uses corner pegging to cause transmissions to occur when the heading changes.

- **Slow Speed:** Lower speed limit (MPH)
- **Slow Rate:** Beacon rate if speed is below "Slow Speed"
- **Fast Speed:** Upper speed limit (MPH)
- **Fast Rate:** Beacon rate if speed is above "Fast Speed"
- **Turn Slope:** The lower the slope, the quicker the BeeLine will transmit due to turning
- **Turn Angle:** Turns less than the turn angle will not be transmitted
- **Turn Time:** Transmissions will not occur within TURN TIME from last transmission.

Profile Switching

There are two profiles that each can contain different transmit parameters. By default, Profile 1 is in effect. If the check box “switch to Profile 2” is enabled, the device will switch to Profile 2 if the altitude is greater than (or less than) the specific value.

After the device has switched to Profile2, the device will switch to Profile 1 if the checkbox “switch to Profile 1” is enabled, the device will switch back to Profile 1 if the altitude is greater than (or less than) the specified value.

This can be used to set a different set of paths and messages depending on the altitude.

The specified APRS ‘Paths’ and the ‘message’ are chosen depending upon which profile is in effect. No other parameters are profile dependent.

On-board memory

The BeeLine GPS includes non-volatile memory for periodic storage of GPS data. Writing always starts at location 0 when power is applied. The previous contents of memory are overwritten.

- **Read Flash:** Data memory is read from the BeeLine GPS and stored to disk in the working directory in a file called beegps.kml. If the file exists, an error is displayed. The .kml file is an ASCII file with headers and footers designed to be compatible with Google Earth.
- **Clear Flash** Erases the on-board flash memory

5 Smart Beacons

Following is a representation of the Smart Beacons algorithm.

```

IF (speed < low_speed)
{
    beacon_rate = slow_rate;
}
ELSE
{
    IF (speed > high_speed) // Adjust beacon rate according to speed
    {
        beacon_rate = fast_beacon_rate;
    }
    ELSE
    {
        beacon_rate = fast_beacon_rate * high_speed / speed;
    }

    // Corner pegging - ALWAYS occurs if not "stopped"
    // Note turn threshold is speed-dependent

    turn_threshold = turn_min + turn_slope / mph;

    IF ((heading_change_since_beacon > turn_threshold) AND
        (secs_since_beacon > turn_time))
    {
        secs_since_beacon = beacon_rate;
    }
}

IF (secs_since_beacon > beacon_rate)
    // ... send beacon

```

More information on SmartBeaconing can be found at <http://www.hamhud.net> .

Here are some suggested values for the various smart beaconing parameters.

Slow Speed: 5	Slow Rate: 3600	
Fast Speed: 60	Fast Rate 60	
Turn Slope: 255	Turn Angle: 22	Turn Time: 5

If your speed is less than 5 mph, transmit a packet once per hour (3600 seconds). If your speed is between 5 mph and 60 mph, transmit once every minute if speed is greater than 60, and longer if your speed is between 5 and 60 (beacon rate = Fast Rate * Fast Speed / actual speed)

If your speed is greater the 5 MPH, also transmit when the heading changes by more than 22 degrees, but not more often than once every 5 seconds.

6 Periodic Operation

If *slotting* is enabled, then the smart beaconing algorithm will not be enabled, and instead the device will transmit a periodic packet at the “slow rate” regardless of the speed of the device.

7 Time Slotting

Time slotting is a method which allows multiple transmitters to share the same frequency, and should only be used with periodic operation. If Time Slotting is enabled, the transmitters will synchronize their transmit times to the GPS clock.

For example, if you set up a transmitter ‘A’ for periodic operation every 30 seconds, set the time slot to 10 and enable slotting, it will transmit at 10 and 40 seconds past the top of every minute.

If you then set up a transmitter ‘B’ or periodic operation every 30 seconds, set the time slot to 5 and enable slotting, it will transmit at 5 and 35 seconds past the top of every minute.

8 APRS symbols

The default ‘-’ symbol will show up as a house. Change it to ‘O’, for example, to display a balloon.

Only the primary APRS symbol table is implemented.

!	"	#	\$	%	&	'	()	*	+	,	-	.	/	0
1	2	3	4	5	6	7	8	9	:	;	<	=	>	?	@
A	B	C	D	E	F	G	H	I	J	K	L	M	N	O	P
Q	R	S	T	U	V	W	X	Y	Z	[\]	^	_	`
a	b	c	d	e	f	g	h	i	j	k	l	m	n	o	p
q	r	s	t	u	v	w	x	y	z	{		}	~		

Choosing a character from the table above causes the symbol in the corresponding position from one of the tables below to be displayed. The cross-hair symbols occupy symbol slots that have not yet been assigned.

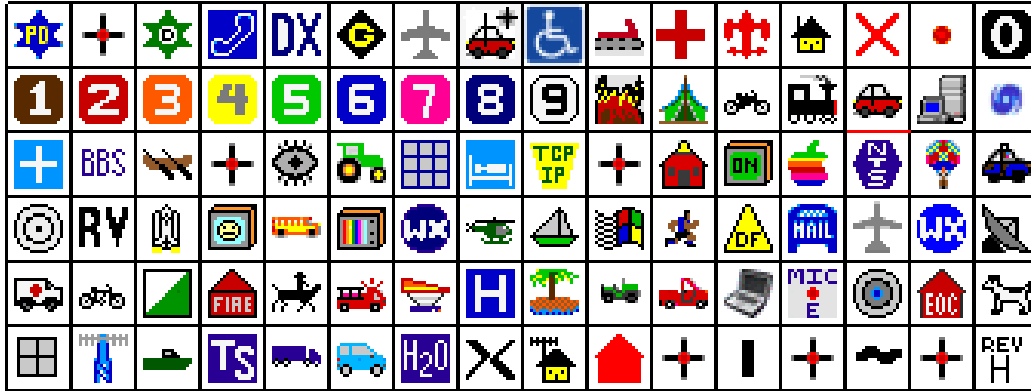

9 Power

Power is delivered via the 3-pin connector near the bottom of the board. Two power input modes are available.

9.1 Low Voltage Input

This pin is intended to be used for truly portable operation. The input voltage in this mode is a minimum of 4 V volts and a maximum of 9.2 Volts. This input pin directly powers the RF amplifier and 3.3volt regulator that in turn drive the GPS, microcontroller, and RF sub-sections. *Applying greater than 9.2Volts on this set of input pins will violate the maximum rating for the power amplifier and possibly damage it.*

Use this power input pin for battery operated applications.

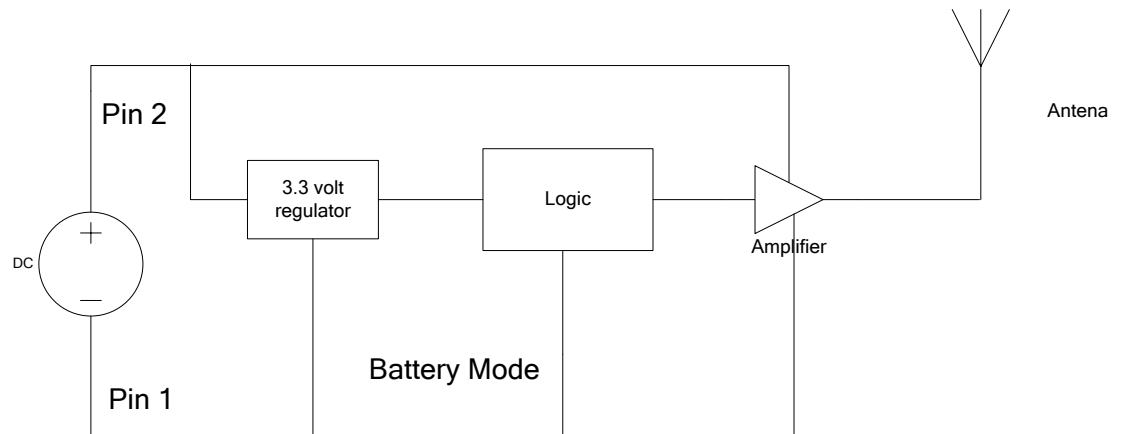

9.2 Hi Voltage Input

This pin is intended to be used for mobile operation and can be plugged directly into an automobile cigarette lighter, or any other unregulated 12 Volt power source. The input voltage in this mode is a minimum of 9 volts, and a maximum of 16 volts. This input drives a 7.5V regulator, which is then routed to the RF amplifier, and also to the 3.3 V regulators as described above.

Use this power input pin for operation from a 12V supply.

If the Hi Voltage input mode is not needed, the large regulator and heat sink on the back of the board may be removed.

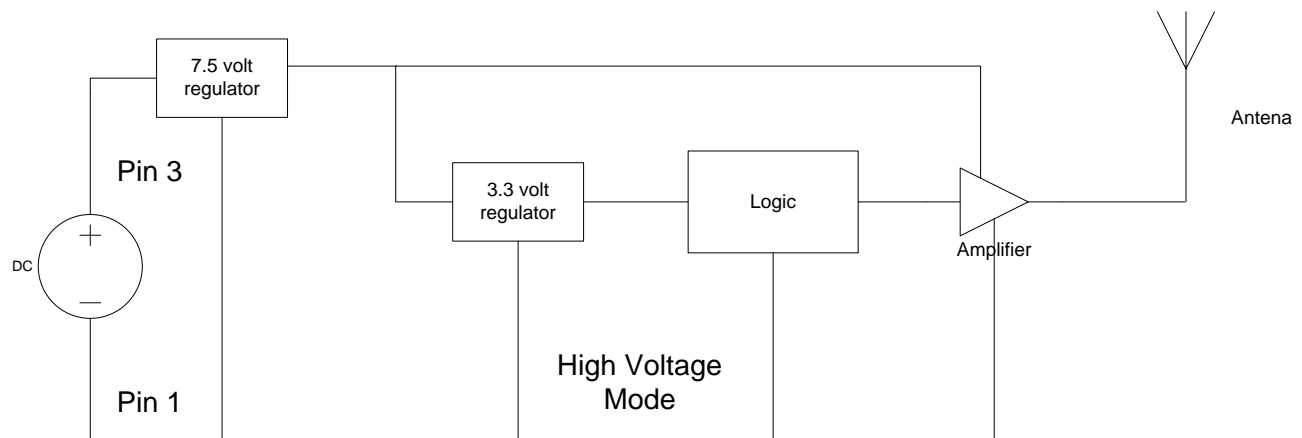

9.3 Power Delivery Summary

There are several ways to power the BeeLine GPS.

- 1) Supply no less than 4.0 Volts to pins 1 and 2 as mentioned in section 9.1. This will result in approximately 1 watt of RF output. It is important that the input voltage not drop below 4V or the output power will drop dramatically. The power regulator is not required in this mode of operation and may be removed if necessary.
- 2) Supply no less than 7.5 Volts and no more than 9.0 Volts to pins 1 and 2 as mentioned in section 9.1. This will result in approximately 5 watts of RF output. The power regulator is not required in this mode of operation and may be removed if necessary. Voltage levels between 4.0 V and 7.5V will result in RF output levels of between 1 and 5 watts.
- 3) Supply no less than 8.5 Volts and no more than 9.6 Volts to pins 1 and 3 as mentioned in section 9.2. This will result in approximately 5 watts of RF output. The power regulator is required, but the heatsink is not required and may be omitted if necessary.

- 4) Supply up to 15.0 Volts to pins 1 and 3 as mentioned in section 9.2. This will result in approximately 5 watts of RF output. The power regulator is required. The heatsink is required.

10 Model and Version Numbers

With the introduction of new hardware to support high RF power output levels and 2 meter / 70 centimeter version, there are now many different models available. The model number and firmware revision will be visible in the windows programming utility and are summarized here

Model Number	Frequency (Mhz)	Amplified?	Digital Telemetry?	12.5V Operation	RF chip
BLGPS0	440	No	Yes	No	CC0150
BLGPS1	440	Yes	G-switch	No	CC0150
N/A	144	No			ADF7012
BLGPS9	144	Yes	No	Yes	ADF7012
N/A	440	No			ADF7012
BLGPSB	440	Yes	No	Yes	ADF7012

It is important to note that even though the PCB's for model numbers BLGPS9 and BLGPSB are the same, the component values differ slightly. It is not possible to load firmware intended for the BLGPS 9 board onto the BLGPSB board.

11 Heat sink

The 2 Meter GPS Transmitter can be powered by two different voltage sources; a 7.5V power source or a 12V power source. If a 12 V power source is used, an onboard regulator is used to convert the 12V input to 7.5V. This regulator requires a heat sink to maintain a safe operating temperature.

The "automotive" version of this device is intended to be connected directly to a 12V power source. This version has the heat sink installed by default

The "mobile" version of this device is intended to be connected directly to a 7.5V power source. This version does NOT have the heat sink installed, but is included in your order. **If you intend to use this version with a 12 V supply, please make sure to install the heat sink.**

The onboard regulator is present on all devices (it's the large 3-pin terminal device on the back of the board).

12 Firmware upgrade

The firmware upgrade utility is a Windows Console application. Open a command window (Start->Run->cmd), and make sure that the flash utility (beeflash.exe) and the appropriate .hex file are in the same directory.

The command line is:

```
C:> beeflash.exe <comm port> <hexfile> [-v]
```

For example:

```
C:> beeflash.exe com1 gspfsk.hex
```

- 1) Remove all power connectors and cables
- 2) Connect the serial interface to the PC
- 3) Plug the serial interface into the BeeLine GPS
- 4) Invoke the flash upgrade utility
- 5) Follow the on-screen directions.

The flash programming utility will check the model number of the current board, and ensure that the correct firmware is being loaded. It will also check for incompatible firmware revisions within the same model number.

```

C:\WINDOWS\system32\cmd.exe

BeeLine GPS Flash Update Program, Version 0.2
=====+=====

Warning: You are about to update the firmware on your BeeLine GPS!

--> NEW FIRMWARE UERSION 111
--> FOR HARDWARE MODEL 9 <2-meter amplified adf7012>

Make sure the BeeLine GPS is powered OFF.
Connect the serial cable to the BeeLine GPS.
Enter 'B' to continue <or 'C' to test>

BeeFlash> B

--> Good, now apply power to the Beeline

GPS power detected.
Waiting for GPS to respond, this could take 5-10 seconds...
Getting model and firmware version...

--> CURRENT FIRMWARE UERSION 111
--> CURRENT HARDWARE MODEL 11 <70-centimeter amplified adf7012>

ERROR: MODELS DO NOT MATCH!
Exiting program

C:\usr\greg\MSC\beeflash\Debug>_

```

13 Connectors

13.1 Power Connector

(looking down from above)

Pin 1: Battery - (GROUND)

Pin 2: Battery + (Low level Voltage)

Pin 3: Battery + (High level Voltage)

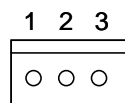

13.2 ICSP Connector

(looking down from above)

Pin 1: TTL level transmit data out (ICSP_DCLK)

Pin 2: TTL level receive data in (ICSP_DATA)

1 2 3

1 2 3 4 5

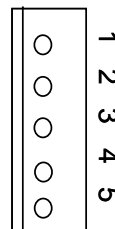

14 Electrical Characteristics

V _{min}	Minimum Voltage Input Level	4.0 Volts
V _{Max} (low V input)	Maximum Voltage Input Level	9.6 Volts
V _{Max} (high V input)	Maximum Voltage Input Level	16 Volts
I _(idlegps)	Idle Current Draw (GPS enabled)	50 mAmps
I _(idle)	Idle Current Draw (GPS disabled)	6 mAmps
I _(tx)	Transmit Current Draw (vGate=3.3V)	1.3 Amps

Measurements below measured with a power input of 8.0 Volts. This table is only relevant if you have control over the vGate pin via a variable resistor installed on your board.

Pout (Watts)	Current (Amps)	vGate (Volts)
0.5		2.5
1	0.6	2.6
2	0.82	2.7
3	0.98	2.8
4	1.1	2.9
5	1.3	3.3

Need power table for V_{in} vs Pout

Need power table for dBm vs Pout